

TRAVERSING CUT-OFF SYSTEM WITH
HOT MELT ADHESIVE APPLICATOR

(2)-MANUALLY ADJUSTABLE GLUE
HEADS (LENGTH AND WIDTH)

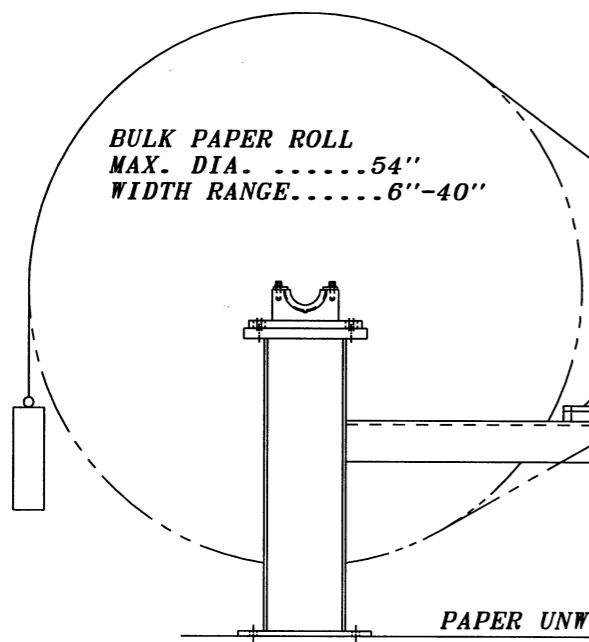

BULK PAPER ROLL
MAX. DIA.54"
WIDTH RANGE.....6"-40"

PAPER UNWIND SECTION

PHOTO-ELECTRIC
INDEXING CONTROL

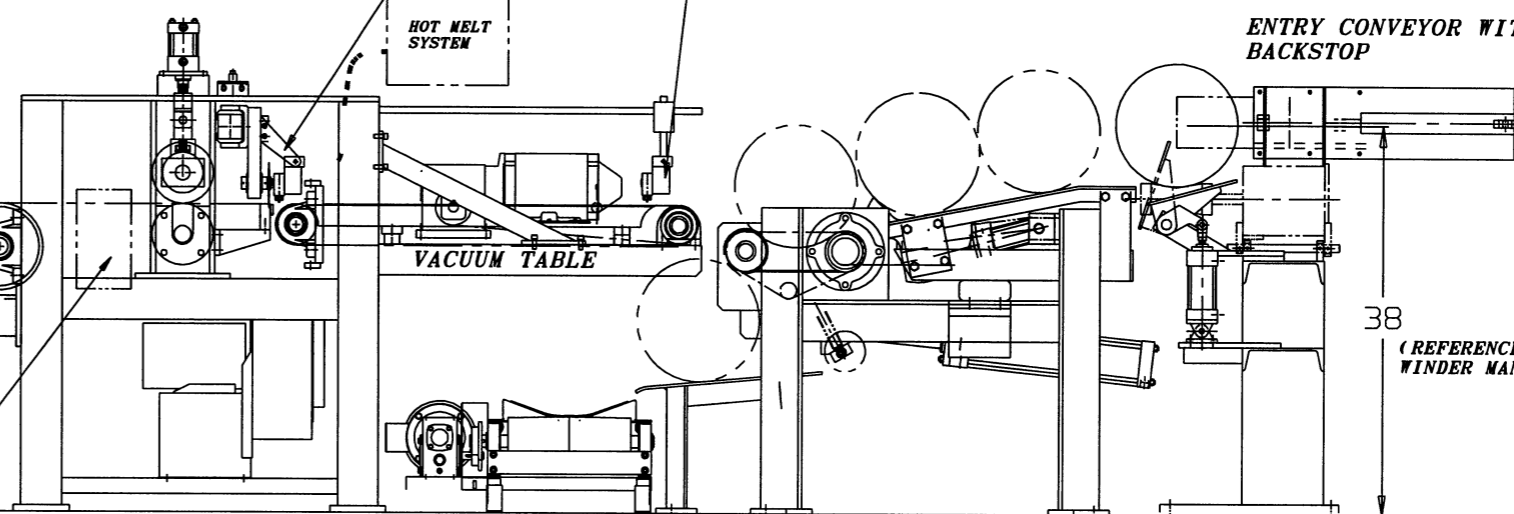

VACUUM TABLE

HOT MELT
SYSTEM

ENTRY CONVEYOR WITH RETRACTABLE
BACKSTOP

38
(REFERENCE: DISCHARGE HEIGHT OF
WINDER MANDREL)

FINISHED PRODUCT EXIT CONVEYOR

The information contained on this drawing is confidential information of Reichel & Drews, Inc., and may not be copied, published, or disclosed to anyone without written consent of Reichel & Drews, Inc.

REF. DWG. UNSPECIFIED TOLERANCES +1 -32 FRACTIONAL +1 -64 2 PL. DECIMAL ± .01 3 PL. DECIMAL ± .005	DRN. MRG	PART NAME FLOOR PLAN	JOB NO.
	DATE 12-29-99	MACHINE AUTOMATIC ROLL WRAPPING SYSTEM	QTY. RECD.
	SCALE		DRAWING NO. E38973A00
REV LETTER DATE DESCRIPTION BY	1025 West Thorndale Avenue, Itasca, Illinois 60143-1385		